

DT SWISS

F 535 44 MM *(FROM 2023)*

TECHNICAL MANUAL

V2023.05

1. GENERAL	3
2. SERVICE AND CARE	5
3. TROUBLE SHOOTING.....	6
4. SMALL SERVICE	7
5. CONVERTING THE CONTROL ELEMENTS FROM MANUAL TO REMOTE .	18
6. CONVERT THE CONTROL ELEMENTS FROM REMOTE TO MANUAL.....	24
7. ADDING / REMOVING APT VOLUME SPACERS.....	27

1. GENERAL

1.1 VALIDITY

This manual describes the component specified on the front page and the footer. This manual is valid for the design of the product as of 08.05.23. Deviations are possible and all items are subject to technical changes.

1.2 SAFETY

The safety instructions are classified as follows:



DANGER

...indicates a hazardous situation that, if not avoided, will result in death or serious injury.



CAUTION

... indicates a hazard with a medium level of risk which, if not avoided, may result in minor or moderate injury.



NOTE

... indicates a potentially hazardous situation that may result in damage to property.

1.3 TARGET GROUP

This manual is intended for the user of the component and dealers. This manual offers the experienced user the possibility to carry out minor service work himself. If you have any doubts about your own abilities, you should definitely contact an expert or a DT Swiss Service Center. Any warranty claims will lapse if work is not carried out properly.

1.4 LAYOUT

The cover page and the footing provide information about the type of product and manual as well as the version of the manual. The DT Swiss contact details can be found on the back. A list of all DT Swiss service centers can be found at www.dtswiss.com.

This manual is intended for being printed as an A5 booklet. Only print this manual if electronic usage is not possible.

1.5 GENERAL MAINTENANCE INFORMATION

Unless otherwise specified, moving parts, threads, O-rings and sealings must be greased before assembly.

CLEANING

For an optimal result of the maintenance works, every component that will be disassembled must be cleaned. Only use cleaners and degreasers which do not damage the components. Especially the cleaning of O-rings and sealings requires mild cleaners. Observe the instructions for use of the respective cleaner.

DT Swiss recommends the following cleaners:

- Motorex Rex
- Motorex Swissclean
- Motorex OPAL 2400, 3000 OPAL, OPAL 5000

Use soap water or similar mild cleaners for external cleaning.

TOOLS

To ensure a damage-free mounting and dismounting of the components, only use the tools which are mentioned in this manual. Special tools are indicated at the beginning of a chapter in the table "Required material".

The use of different tools is at the discretion of the user. If components are damaged by the usage of differing tools, the user is liable.

DT Swiss special tools are precision tools. Damage-free mounting and dismounting of the components can only be ensured if the tools are working properly and if the condition of the tools are perfect. Always keep the tools in their original packaging or adequate devices to prevent damage.

1.6 ENVIRONMENTAL PROTECTION

The statutory regulations shall apply. Whenever possible, avoid creating waste. Waste, especially carbon, lubricants, cleaners and any other fluids must be disposed in an environmentally compatible manner. Only print this manual if electronic usage is not possible.

1.7 EXCLUSION OF LIABILITY

The activities listed in this manual may only be carried out by persons with sufficient specialist knowledge. The user is liable for any damage or consequential damage caused by wrongly maintained or installed components. If you have doubts, please contact an expert or your region's DT Swiss pro level service center.

1.8 WARRANTY

Warranty conditions can be found at www.dtswiss.com.

2. SERVICE AND CARE

2.1 SAFETY



DANGER

RISK OF INJURY DUE TO WRONG MAINTENANCE OF THE FORK!

Incorrect maintenance or assembly of the fork can lead to incorrect function!

- Maintenance and assembly may only be done by a skilled professional.
- In case of any doubt, contact a DT Swiss service center.
- Only use original spare parts.

2.2 SERVICE INTERVALS

If service intervals are not respected, any warranty claims can be denied.

Task	Interval
Full service carried out by a DT Swiss service center	Annually or after 200 operating hours
Small service (see “4. Small Service” on page 7)	50 operating hours more frequently in case of extreme operating conditions.
Check fork for damage and cracks. If there is any damage, contact the DT Swiss Service Centre.	Before and after every ride and after a crash
Check the fastening is correct / check tightening torques	Before each ride
Check the functionality	Before each ride
Care (see below)	After each ride

2.3 CARE AND CLEANING

The following care and cleaning instructions must be observed:

- Clean the fork with a damp cloth after each ride.
- Remove dirt accumulations in the area of the wiper seals.
- Never use aggressive cleaners that damage the wiper seals.
- Do not use high-pressure cleaners. Water and dirt can get into the fork and damage it!
- Remove all visible, dried dirt from the area of the wiper seals. This will prevent dirt from getting into the fork.
- Additional lubrication of the fork in the area of the wipers from the outside is not necessary.

3. TROUBLE SHOOTING

Issue	Reason	Solution
The fork is not responding properly.	The bedding-in time is not over.	Bedding-in time is about 20 operating hours.
	The air pressure is too high.	Decrease the air pressure controlled using a suitable shock pump.
	The fork needs a small service.	Carry out a small service (see "4. Small Service" on page 7) yourself or by your dealer or a DT Swiss service center.
The fork bottoms out on moderate bumps.	The air pressure is too low.	Increase the air pressure controlled using a suitable shock pump.
The full travel of the fork cannot be used.	The air pressure is too high.	Reduce the air pressure.
	Wrong measurement of the travel. Some forks do not use the full stroke of the stanchions.	Always measure the distance between wiper seal and SAG O-ring.
The fork does not rebound completely and hardens on fast repetitive bumps.	Too much rebound damping.	Decrease rebound damping.
The fork rebounds too fast, the front wheel loses contact to the ground after bumps or it slides in turns.	Not enough rebound damping.	Increase rebound damping.
The lockout does not work well.	Leaks inside the cartridge.	Contact your local dealer or the responsible DT Swiss service center to solve this problem.
	Remote Lockout: The lockout cable is not tensioned correctly.	Check the proper fixation and the tension of the lockout cable.

If the problem cannot be solved, contact a DT Swiss service center!



4. SMALL SERVICE

PREPARATORY STEPS

Clean the fork

Link

["Cleaning" on page 4](#)

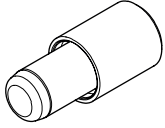
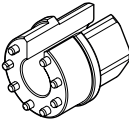
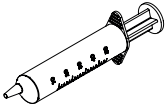
Required tools and materials	Specification	Quantity	Article number
wiper seal kit Ø35 <ul style="list-style-type: none"> • 2 x wiper • 2 x foam ring • 2x O-ring 		1	FWKXXXXXXXXX47117S
DT Swiss Lube Fluid		100 ml	4064XXXXXXXXX000026
DT Swiss Fork Oil		100 ml	4064XXXXXXXXX000024
wiper seal mounting tool		1	FWTXXXXXX10015661S
mounting tool for spring unit		1	FWTXXXXXX10044447S
syringe (minimum volume 20 ml)		1	-
tire lever		1	-
degreaser		-	-
torque wrench 25 Nm		1	-
plastic hammer		1	-
shock pump		1	-

4.1 RELEASING THE AIR

1. Unscrew the valve cap.

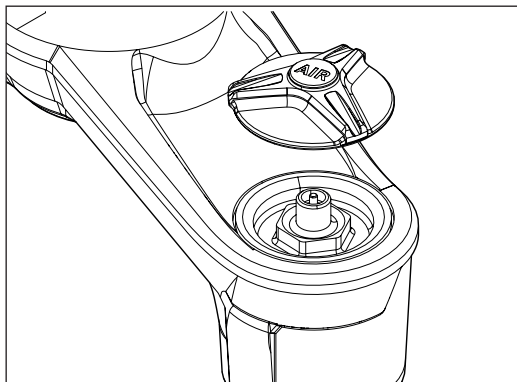

2. Gently press on the valve core with a suitable tool and slowly release the air.

3. Slowly compress the fork two times about 10 mm with the valve insert pressed and pull it apart again.

→ This balances the positive and negative air chambers.

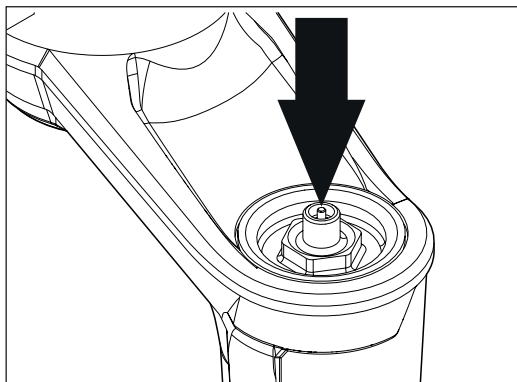

4.2 DISASSEMBLING THE LOWER UNIT

1. Ensure that the air has been released completely (see "4.1 Releasing the air" on page 8).

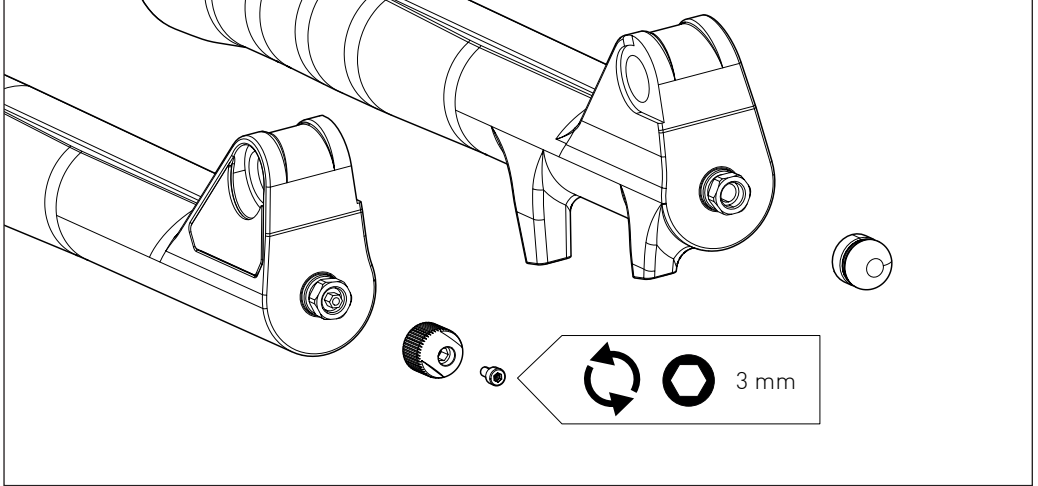

2. Hold the rebound adjuster with an 11 mm open-end wrench, unscrew the rebound adjuster screw and pull it off.
3. Pull off the protective cap on the spring side.

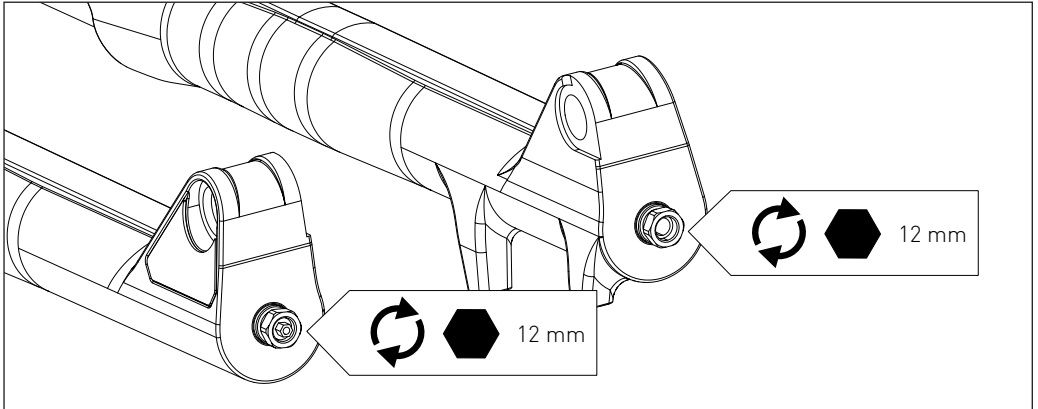

→ Turn the two screws clockwise into the lower unit using a 12 mm socket.

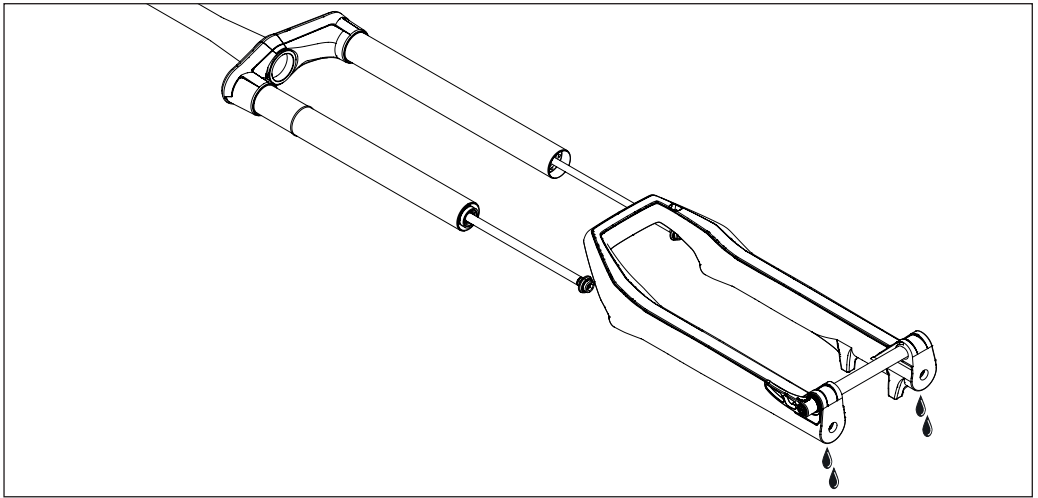

4. Remove the lower unit carefully.
5. Collect the leaking oil using a suitable container.
6. Remove the O-rings of the connectors. If there is no O-ring on one of the connectors, it may be inside the lower unit and must be removed from there.
7. Lightly grease the O-rings and place them on the connectors.

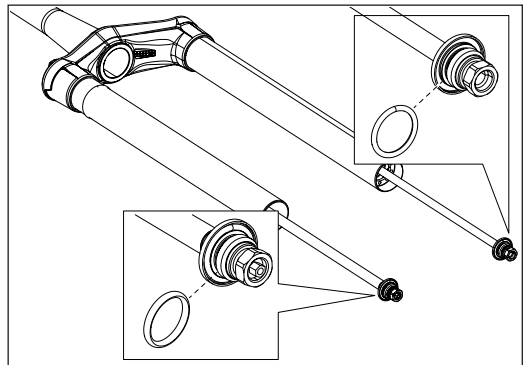

4.3 CHANGING THE WIPER SEALS

1. Remove both foam rings below the wiper seals.

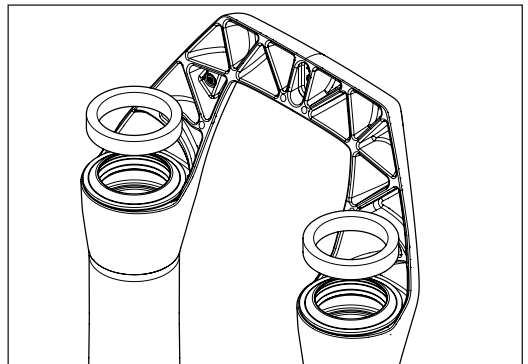

2. Remove both wiper seals using a solid tire lever.

ATTENTION: The lower unit must not be damaged!

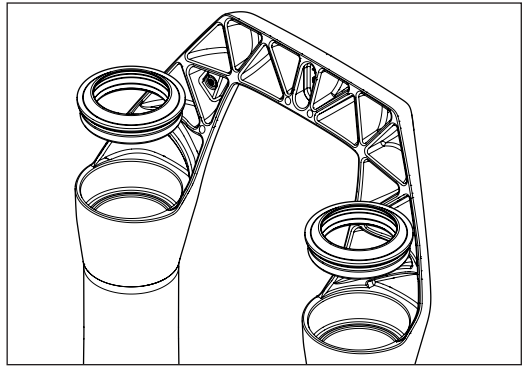

3. Clean the lower unit with an appropriate cleaner.

- If you are using soap water, flush the lower unit with clear water after cleaning.
- There must be no residual moisture inside the lower unit before re-mounting.
- Only use lint-free textile cloths.

4. Degrease the seats of the wiper seals in the lower unit.

5. Slide the tool FWTXXXXXX10015661S into the first wiper seal.

6. Carefully drive in the wiper seal using a hammer.

7. Remove the tool from the wiper seal.

8. Repeat steps to mount the second wiper seal.

9. Leave the lower unit for about 15 minutes and allow the wiper seals to seat.

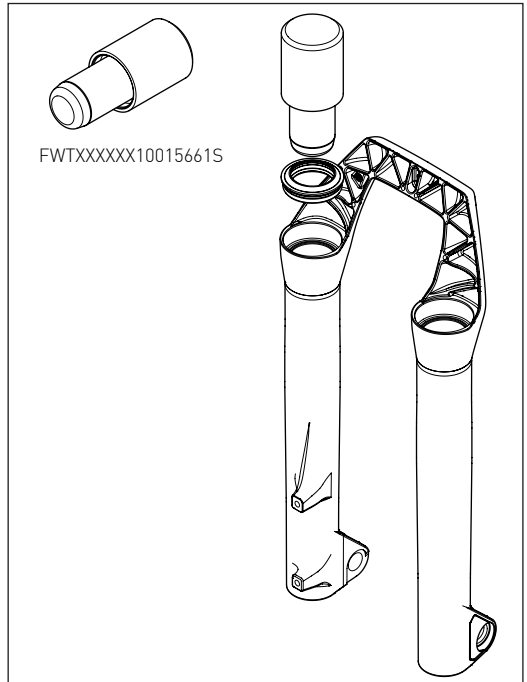

10. Put two new, in DT Swiss Lube Fluid soaked foam rings between the bushings and the wiper seals.
- Make sure that the foam rings are not twisted and completely evenly between seal and bushing.

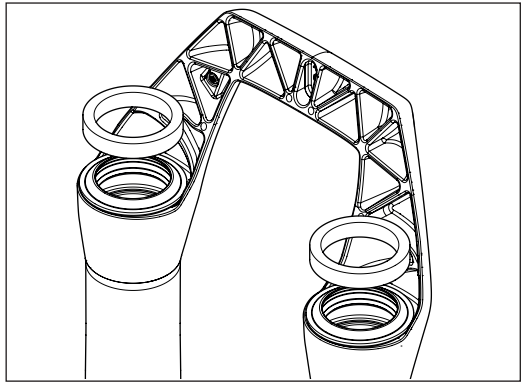

4.4 REMOVING THE SPRING UNIT

As part of the small service we recommend to remove the spring unit in order to remove introduced lubricating oil from the spring unit and from the left stanchion.



DANGER

RISK OF INJURY FROM PRESSURIZED COMPONENTS!

If the spring unit or the air chamber cap is removed without first releasing the air, the spring unit or the air chamber cap is ejected from the stanchion after loosening the screw connection.

- Release the air completely before unscrewing the spring unit or the air chamber cap.
- While deflating the air, move the fork several times through the travel and deflate the air again (see "4.1 Releasing the air" on page 8).
- Components that may be under pressure must never point towards the face or body during disassembly.

1. Ensure that the air has been released completely (see "4.1 Releasing the air" on page 8).
2. Clamp the fork in a suitable device so that the open sides of the stanchions point downwards.
3. Using the tool FWTXXXXXX10044447S, unscrew the spring unit from the underside of the left stanchion.
4. Drain the oil from the stanchion and the spring unit.

It is not necessary to clean the spring unit or the inner surface of the left stanchion. The remaining oil lubricates the sliding surfaces of the spring unit.

The 130, 140 and 150 mm models have a volume spacer inside the left stanchion. The position of the volume spacer must not be changed and the volume spacer must not be removed.

If the volume spacer has been moved accidentally, it must be positioned so that the distance from the lower edge of the left stanchion to the lower edge of the volume spacer is 247 to 252 mm.

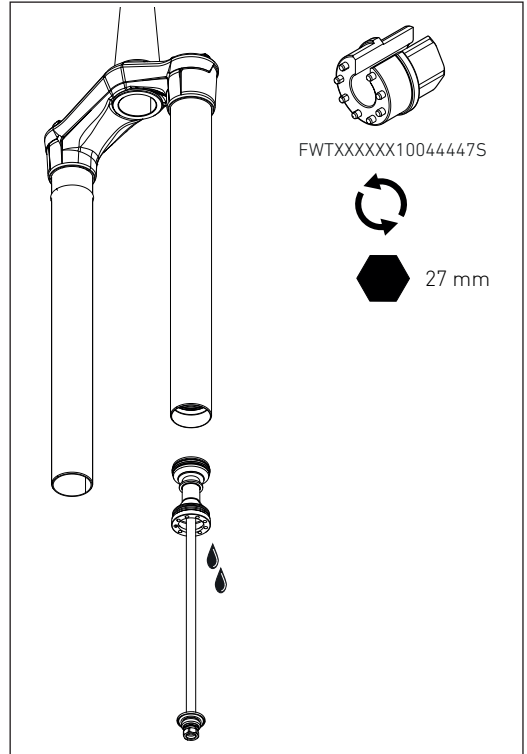

4.5 ASSEMBLING THE SPRING UNIT

1. Make sure that there is still residual oil on the seals of the spring unit. Grease the seals with a small amount of DT Swiss Fork Oil if necessary.
2. Push the screw connection of the spring unit as far as possible in the direction of the piston.

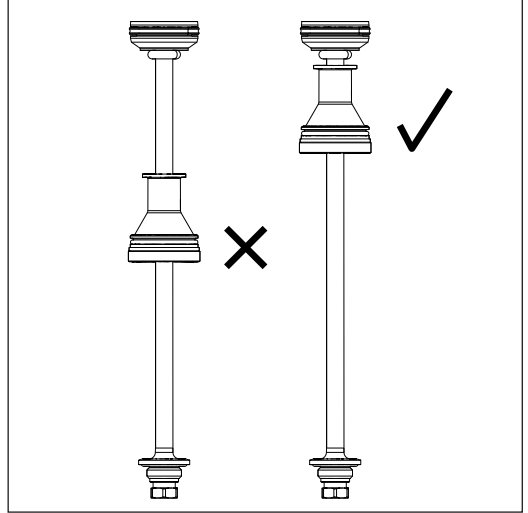

3. Screw in the spring unit from the bottom using the tool FWTXXXXXX10044447S and tighten with a torque of 20 Nm. Make sure that the screw connection of the spring unit is pushed as far as possible in the direction of the piston.

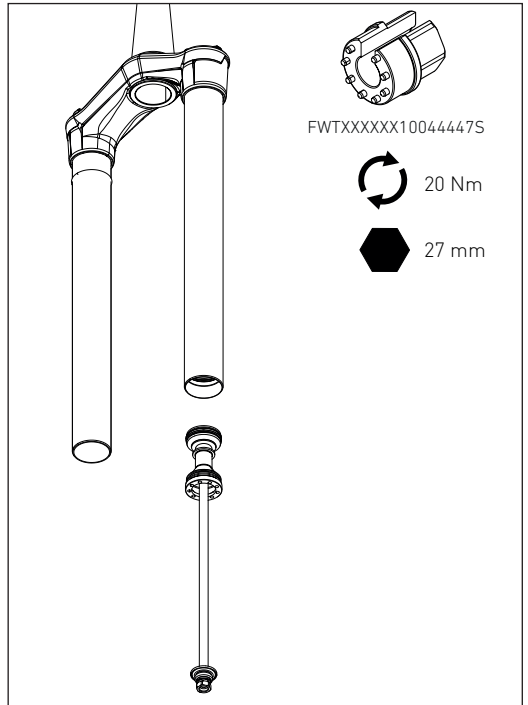

4.6 ASSEMBLING THE LOWER UNIT

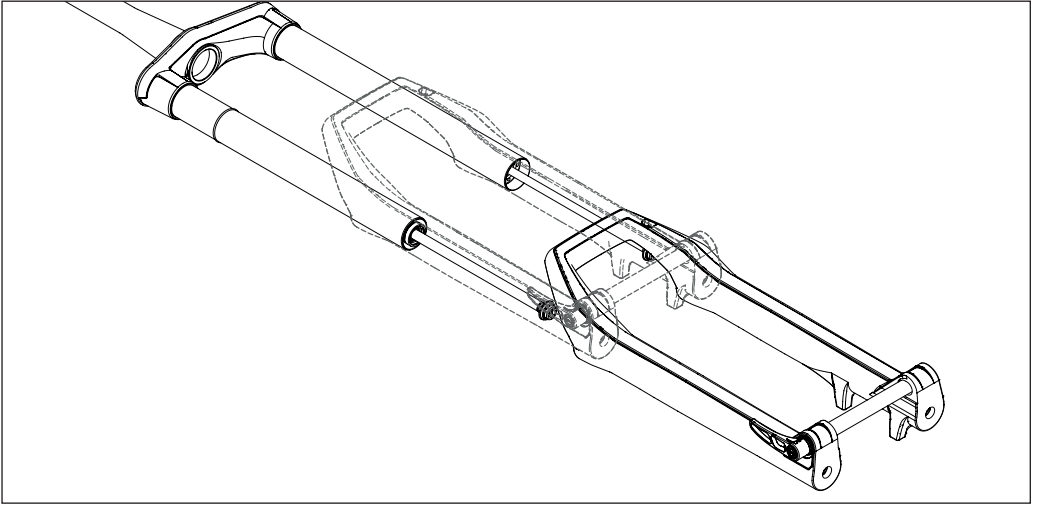

1. Check, if the O-rings of the connectors are still in place.
2. Slide the SAG O-ring onto the stanchion tube if necessary.
3. Slide the lower unit about 5 cm onto the upper unit.

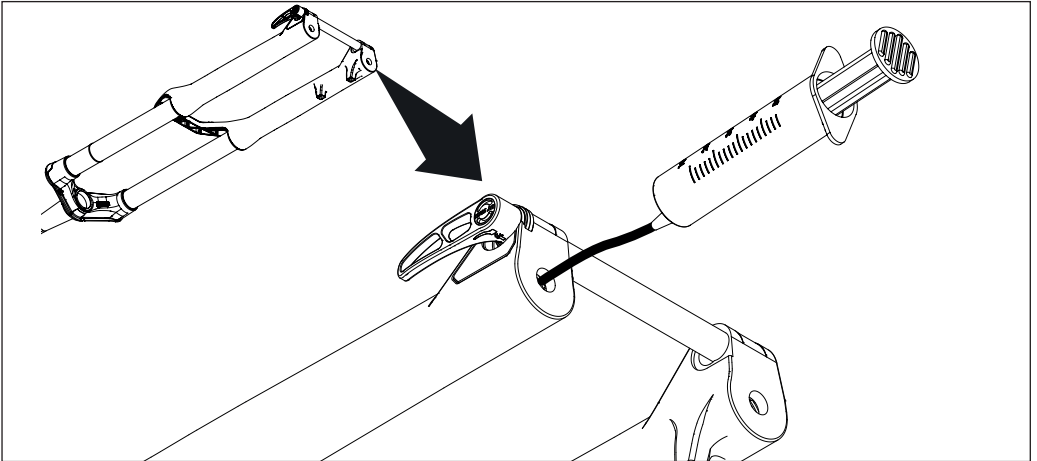

4. Fix the fork 45° - 70° upright.
5. Fill each 20 ml DT Swiss Fork Oil with the help of a syringe in the spring side and in the damping side of the fork.
6. Allow the fork to rest in the previously fixed position for about 60 seconds to allow the bushings to be lubricated.
7. Fully slide the lower unit onto the stanchions.

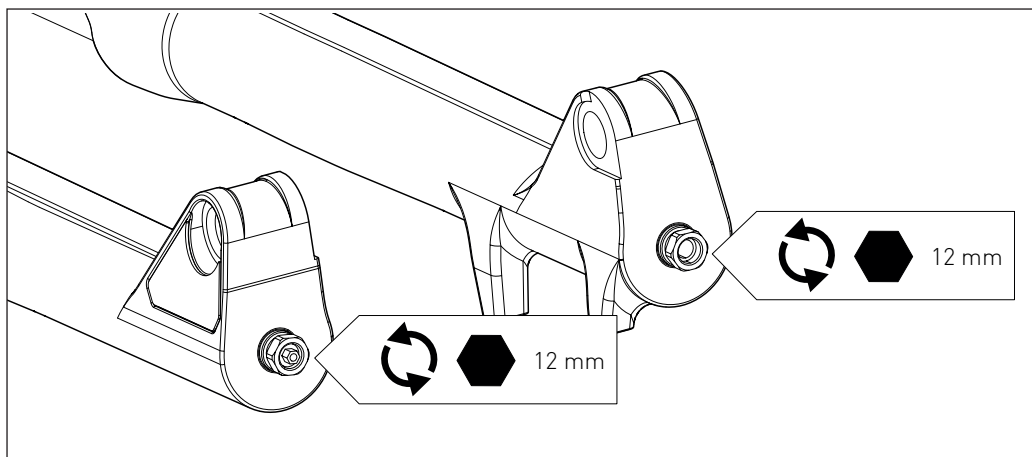

8. Screw in the hexagonal socket screw on the spring and damping side into the lower unit counterclockwise using an 12 mm hex nut and tighten it with a torque of 12 Nm.

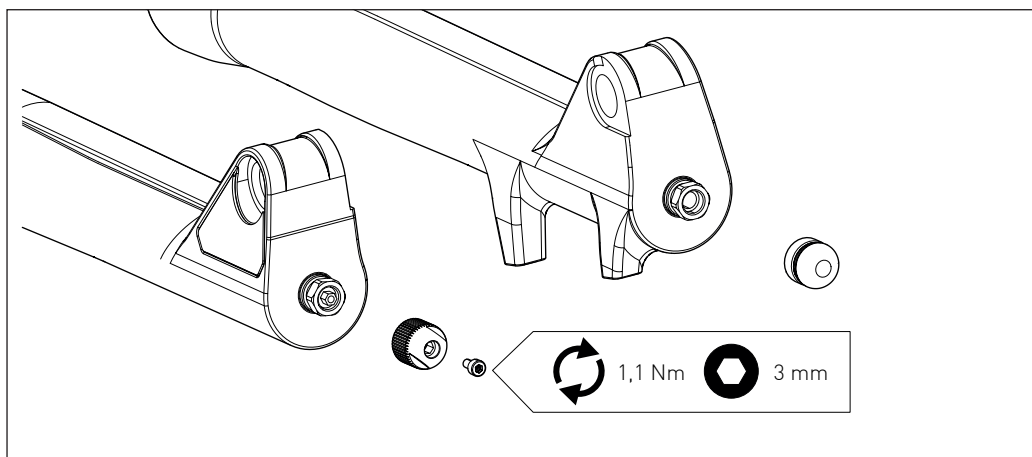

9. Attach the rebound adjuster on the damping side.
10. Put Loctite 241 onto the thread of the fixing screw of the rebound adjuster.
11. Hold the rebound adjuster with an 11 mm open-end wrench, screw in the fixing screw and tighten it to 1.1 Nm.
12. Fit the protective cap on the spring side.

4.7 INFLATING THE FORK

1. Inflate the fork (see user manual for detailed information).
2. Screw on the valve cap.

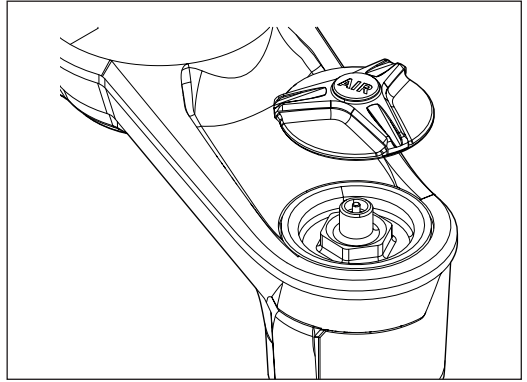

5. CONVERTING THE CONTROL ELEMENTS FROM MANUAL TO REMOTE

5.1 REQUIRED TOOLS AND MATERIALS

Required tools and materials	Quantity	Article number / detail
controls kit remote	1	FWXXXXXXXXXX37117S
T6 Torx	1	
2 mm hex key	1	
8 mm socket	1	FXTXXXXXXXXX018645S
torque wrench	1	
thread locker	as required	Loctite 241

5.2 OVERVIEW CONTROLS KIT

- 1 fixing screw
- 2 compression adjuster
- 3 nut
- 4 remote wheel
- 5 clamping screw for remote cable
- 6 spring
- 7 dust seal
- 8 cable guide
- 9 O-ring

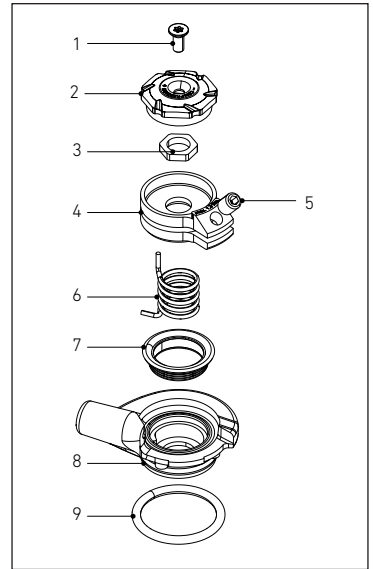

5.3 REMOVING THE MANUAL CONTROL ELEMENTS

1. Unscrew the screw of the compression adjuster with a Torx T6 and remove the compression adjuster.

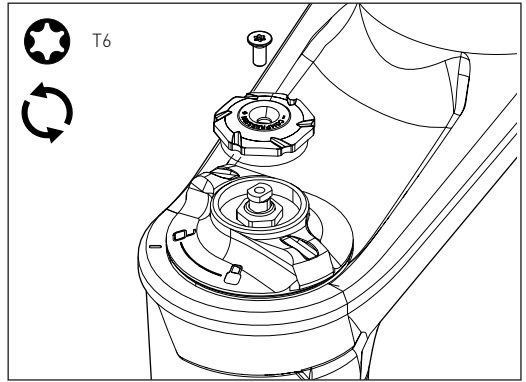

2. Hold the mode lever with one hand.
3. Unscrew the nut using the tool FXTXXXXXXXXX018645S.
→ The lever must not turn while unscrewing the nut!
4. Remove the mode lever and the O-ring underneath.

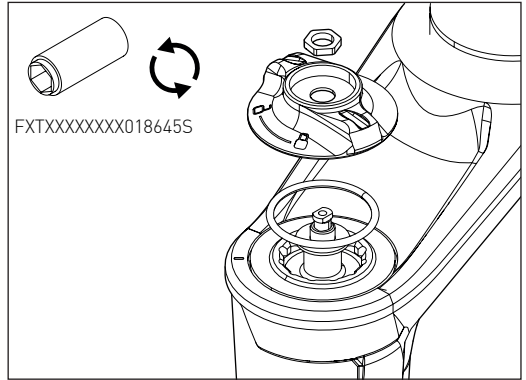

5. Take off the index, the index caps and the springs.

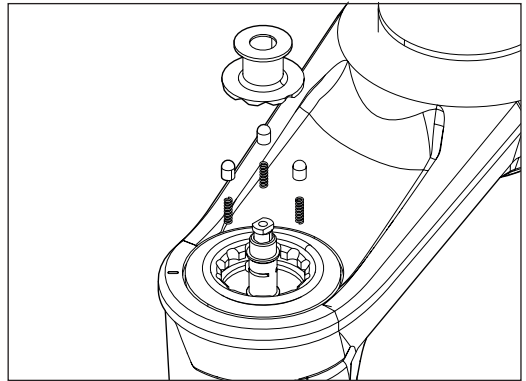

5.4 ASSEMBLING THE REMOTE CONTROL ELEMENTS

1. Clean the top of the damping unit thoroughly.
2. Ensure that the lockout pin is turned until stop in clockwise direction.
→ Turn the lockout pin if needed.
3. Lightly grease the O-ring and insert it into the groove on the top of the damping unit.
→ The O-ring must rest equally in the whole circumference of the groove.
4. Lightly grease the lockout pin.

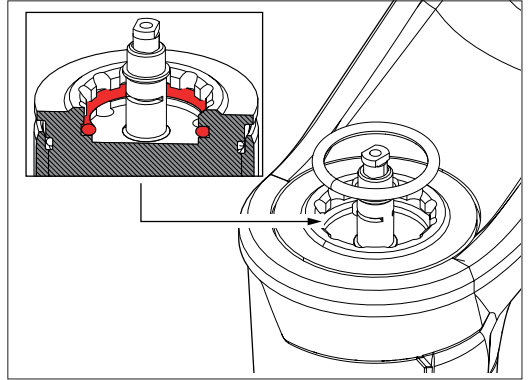

5. Insert the spring into the cable guide.
→ The horizontally angled arm of the spring must rest in the slot of the cable guide.
6. Push the cable guide with the spring onto the damping unit.
→ If the cable guide cannot be pushed in fully, possibly the O-ring is not positioned correctly (see step above).

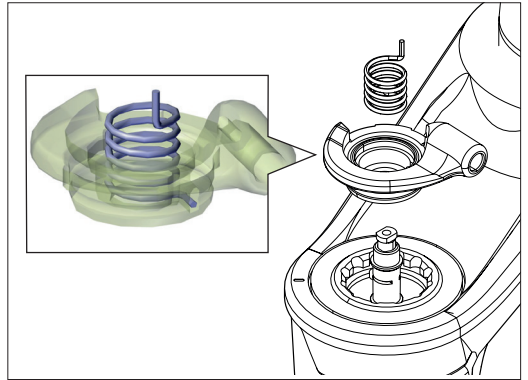

- The cable guide must rest fully on the fork crown.
→ The cable guide must point in riding direction as far as possible to the center of the fork without touching the fork crown.

7. Put the dust seal onto the cable guide.

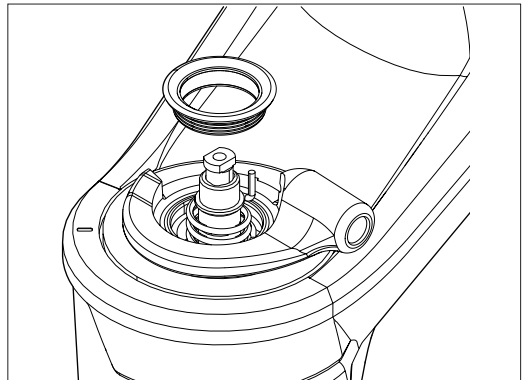

8. Put the end of the spring facing upwards into the bore of the remote wheel.
9. Put the remote wheel onto the lockout pin.
10. Using a 2 mm hex key, turn the remote wheel approx. 180° clockwise over the elevation of the cable guide.
 - Push down the remote wheel while turning.
 - Reduce the pressure before reaching the elevation so as not to damage the cable guide.
 - The rise of the cable guide prevents that the remote wheel turns backwards.
11. Push the remote wheel down in the engaged position and hold it in this position.

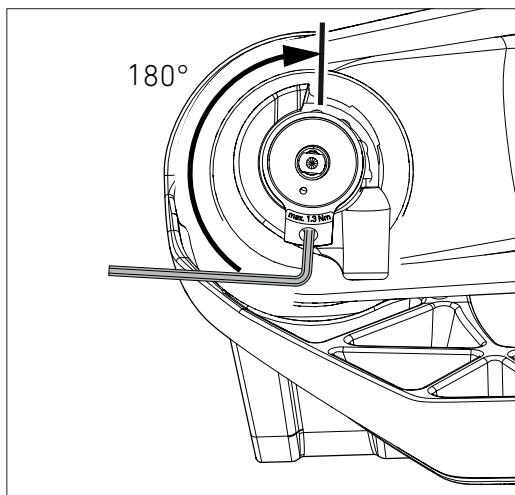

12. Screw the nut onto the pin by hand.
13. Turn the remote wheel into the lockout position using the short end of an angled 2 mm hex key.
 - The remote wheel is in the lockout position when it touches the cable stop (see picture).
14. Screw on the nut clockwise using the special tool FXTXXXXXXXXX018645S and tighten the fixing nut with a torque of 5 Nm.

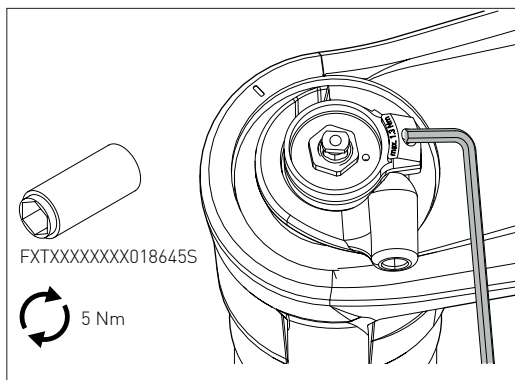

15. Check the correct assembly of the remote wheel: Turn the remote wheel using the short end of an angled 2 mm hex key.
 - The remote wheel must turn from the left stop to the cable stop.
 - If the remote wheel cannot be turned in this angle, the lockout pin is not positioned correctly. Disassemble the remote wheel and turn the lockout pin to lockout position again (see step 2 on page 20).

16. Insert the screw through the compression adjuster and apply Loctite 241 to the threads of the screw.
17. Attach the compression adjuster, hold it with a 17 mm open-end wrench, turn the screw in and tighten it slightly.

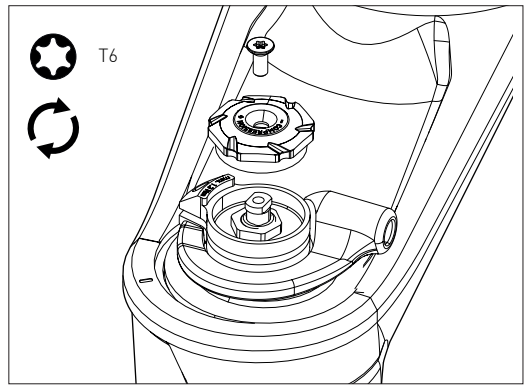

5.5 ATTACHING THE REMOTE CABLE

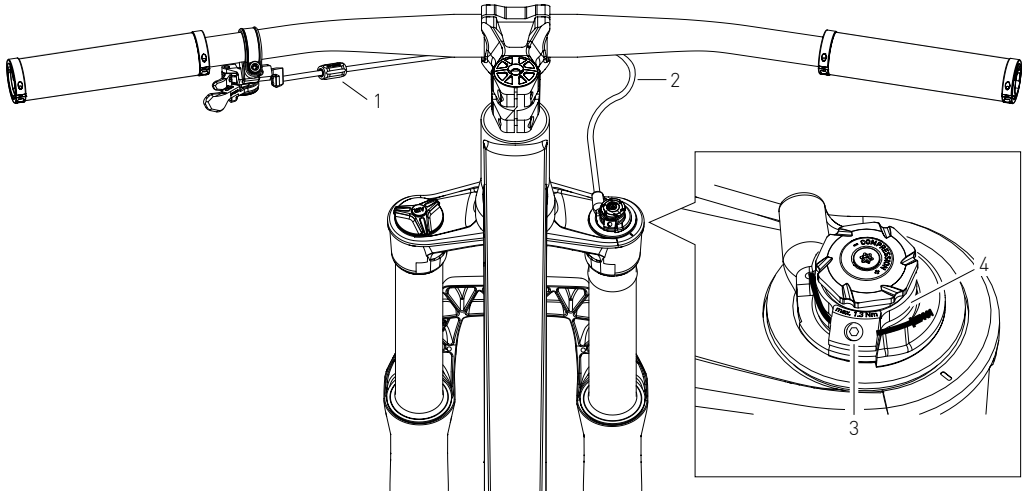

1. Attach the cable housing [2] and the cable adjuster [1].
 - Only cable housings with an outer diameter of 4 mm must be used.
 - Before and after the cable adjuster there must be at least one short piece of cable housing.
 - Screw in the cable adjuster completely and then loosen one turn.
2. Switch the remote lever to position "OPEN" and insert the cable through the cable housing [2].
3. Unscrew the clamping screw [3] on the remote wheel.
4. Guide the cable through the cable stop and place it around the remote wheel [4].
5. Pull the cable tight, clamp it with the clamping screw and tighten the clamping screw with a max. torque of 1.5 Nm.
6. Operate the remote lever several times.
7. Adjust the cable tension with the cable adjuster [1].
 - The remote lever locks in position "LOCK" and activates the lockout.
 - In the "LOCK" position, the remote wheel touches the stop of the cable guide.
8. Shorten the shift cable to the desired length and attach an end cap.

6. CONVERT THE CONTROL ELEMENTS FROM REMOTE TO MANUAL

6.1 REQUIRED TOOLS AND MATERIALS

Required tools and materials	Quantity	Article number / detail
controls kit	1	FWXXXXXXXXXX37114S
T6 Torx	1	-
8 mm bit	1	FXTXXXXXXXXX018645S
17 mm wrench	1	-
torque wrench with a 2 mm hexagon and T6 Torx bit	1	-
thread locker	1	Loctite 241

6.2 OVERVIEW CONTROLS KIT

- 1 fixing screw
- 2 compression adjuster
- 3 nut
- 4 mode wheel
- 5 O-ring
- 6 index
- 7 Index cap
- 8 spring

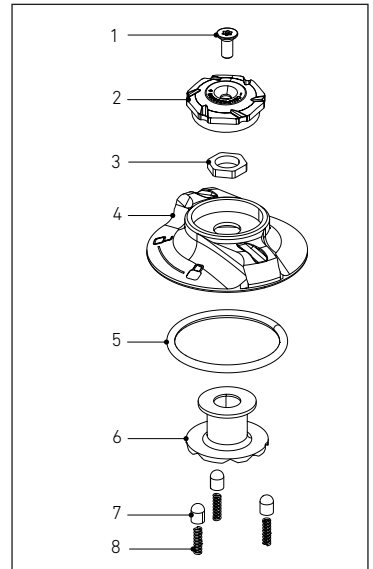

6.3 REMOVING THE REMOTE CONTROL ELEMENTS

1. Release the remote cable and remove it.
2. Hold the compression adjuster with a 17 mm open-end wrench and unscrew the screw with a Torx T6.
3. Take off the compression adjuster.

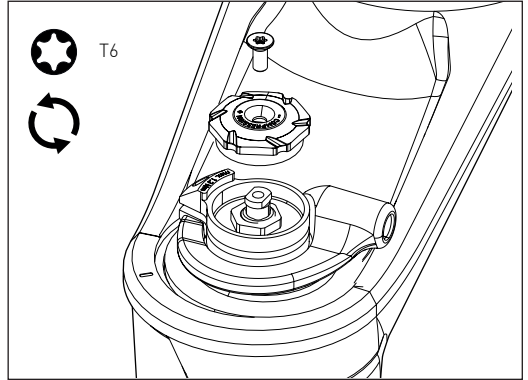

4. Hold the remote wheel.
→ The remote wheel must not turn while unscrewing the nut!
5. Unscrew the nut using the tool FXTXXXXXXXXX018645S.

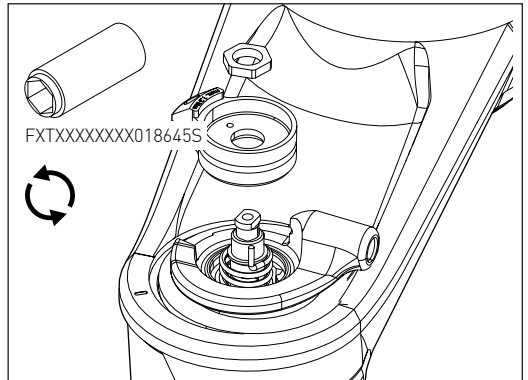

6. Remove the cable guide with dust seal and spring.
7. Take off the O-ring.

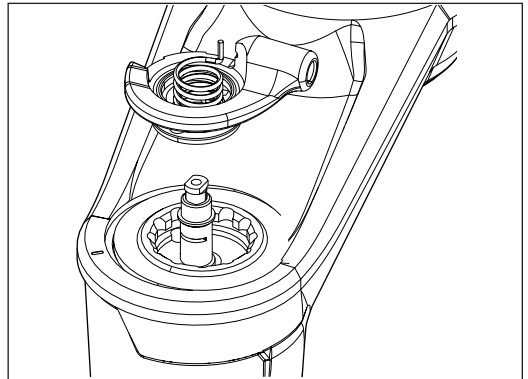

6.4 ASSEMBLING THE MANUAL CONTROL ELEMENTS

1. Clean the top of the damping unit thoroughly.
2. Insert springs and index pins into the bores of the damping unit.
→ The holes must be selected so that the index pins are offset by 120°.
3. Attach the index as shown. One of the three pins must match in the notch direction of the index.
4. Turn the lockout shaft clockwise to its stop (= LOCK position).

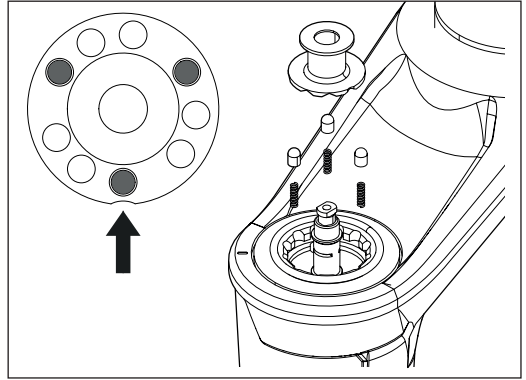

5. Attach the O-ring and the lever.
6. Screw on the nut by hand.
7. Hold the lever in position «LOCK» and tighten the nut with 5 Nm using the tool FXTXXXXXXXXX018645S.
→ The suspension fork is in the "LOCK" position when the lock symbol is aligned with the line.

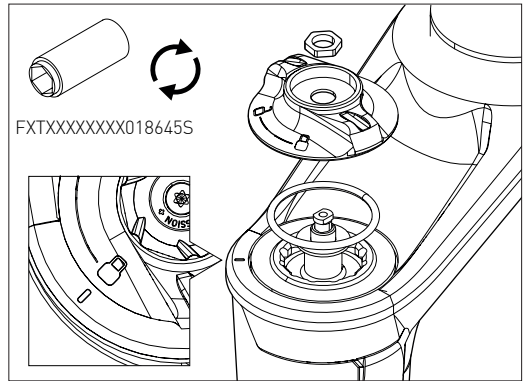

8. Check the damping function of the positions «OPEN» and «LOCK» by compressing the fork.
9. Insert the screw through the compression adjuster and apply Loctite 241 to the threads of the screw.
10. Attach the compression adjuster, hold it with a 17 mm open-end wrench, turn the screw in and tighten it slightly.

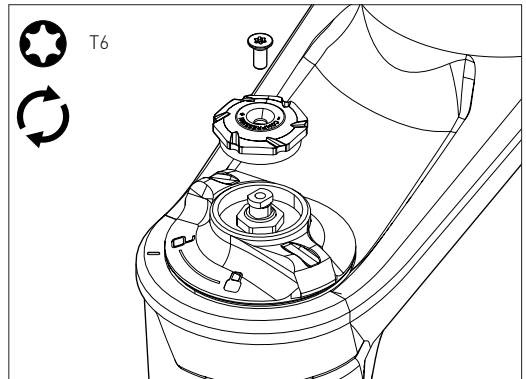

7. ADDING / REMOVING APT VOLUME SPACERS

7.1 OVERVIEW / FUNCTION

The APT (Adaptable Progression Tune) system allows the rider to adjust the progression of the air spring curve by adding or removing volume spacers in the fork's air chamber.

The suspension fork is supplied with one mounted volume spacer. A further volume spacer is included for personal adjustment.

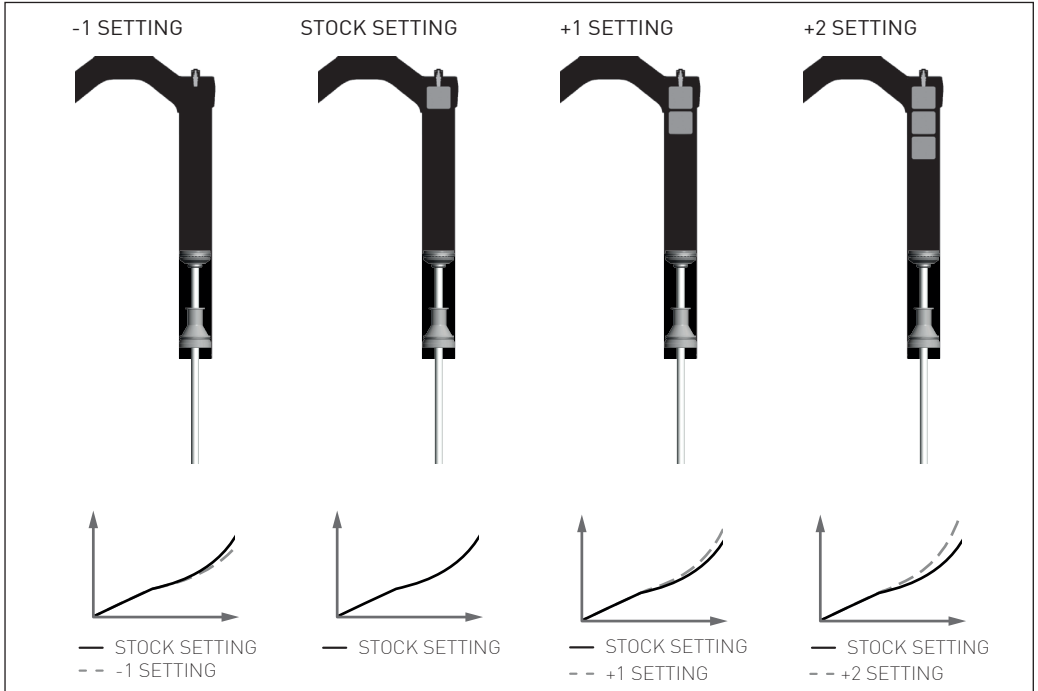

-1 SETTING: COMFORTABLE LINEAR

In this setting, without spacers, the suspension fork has a linear spring curve across the entire stroke and is barely progressive at the end of the travel. It is suitable for moderate off-road use by comfort-oriented riders.

STOCK SETTING: RATHER COMFORTABLE, RATHER LINEAR

More ambitious riders looking for a rather comfortable setting use the setting with a single APT spacer. This offers a spring curve with a low progression for a smooth ride feel.

+ 1 SETTING: RATHER PROGRESSIVE

This setting results in a rather progressive spring curve that gives more experienced riders the support they are looking for with their active riding style.

+ 2 SETTING: VERY PROGRESSIVE

When three APT spacers are used, the fork gets progressive and offers a direct ride feel. That makes this setting suitable for strong riders with an aggressive riding style.

7.2 REQUIRED TOOLS AND MATERIALS

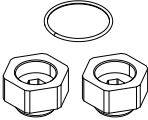
Required tools and materials	Specification	Quantity	Article number
APT adjustment kit F 535		1	FWXXXXXXXXXX44665S
15 mm hexagon socket		1	
28 mm open end wrench		1	
torque wrench 25 Nm		1	

7.3 RELEASING THE AIR

1. Unscrew the valve cap.

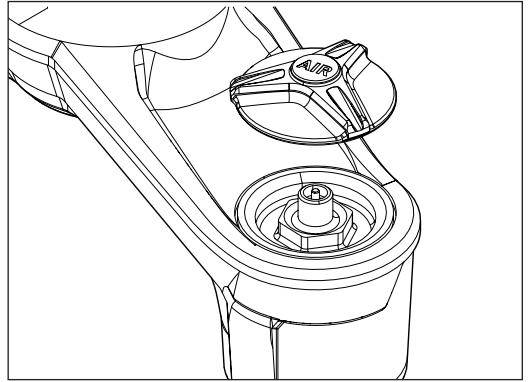

2. Gently press on the valve core with a suitable tool and slowly release the air.

3. Slowly compress the fork two times about 10 mm with the valve insert pressed and pull it apart again.

→ This balances the positive and negative air chambers.

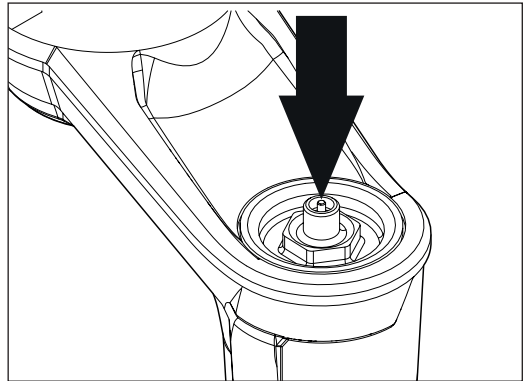

7.4 OPENING THE AIR CHAMBER

1. Ensure that the air has been released.
2. Ensure that the area around the air chamber cap is clean to prevent dirt from entering the air chamber.
3. Unscrew the air chamber cap with a 15 mm hexagon socket and a ratchet.

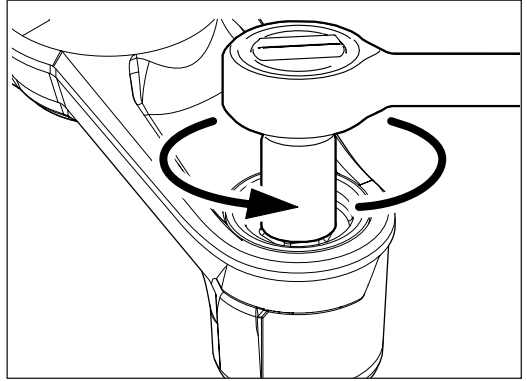

4. Pull the air chamber cap out of the air chamber.

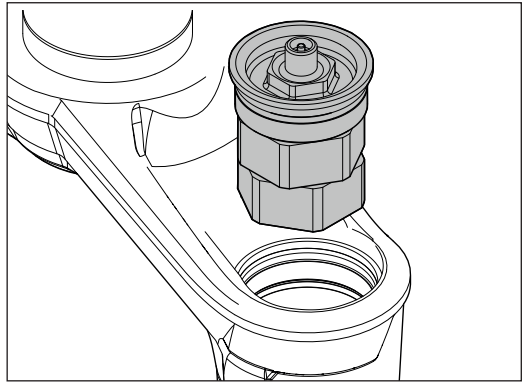

7.5 CHANGING THE O-RING OF THE AIR CHAMBER CAP

1. Remove the O-ring from the air chamber cap.
2. Clean the seat of the O-ring and the thread of the air chamber cap and grease it slightly.
3. Lightly grease the O-ring and pull it onto the air chamber cap

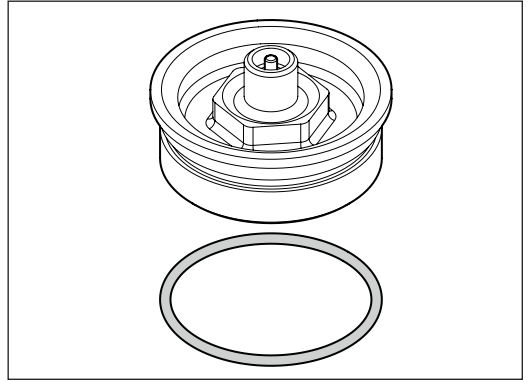

7.6 ADDING / REMOVING APT VOLUME SPACERS



NOTE

RISK OF DAMAGE THROUGH THE INSTALLATION OF MORE THAN THREE VOLUME SPACERS!

If more than three volume spaces are mounted, the fork cannot compress completely.

- Never mount more than three volume spacers!

1. Attach additional volume spacers or remove volume spacers using a 28 mm open-end wrench.
→ The maximum number of three volume spacers must not be exceeded!
2. Tighten the volume spacer with a torque of 2 Nm.

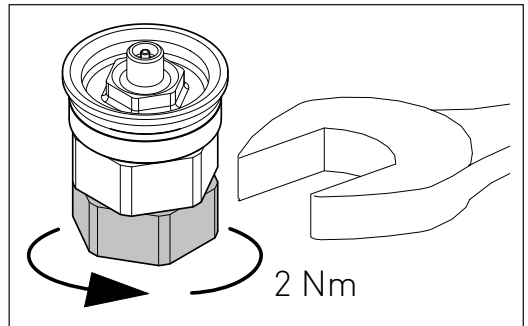

7.7 CLOSING THE AIR CHAMBER

1. Clean the thread of the air chamber and the thread of the air chamber cap.
2. Lightly grease the thread and the O-ring.
3. Screw in the air chamber cap as far as possible by hand.
4. Tighten the air chamber cap with a 15 mm hexagon socket and a torque wrench to a torque of 25 Nm.

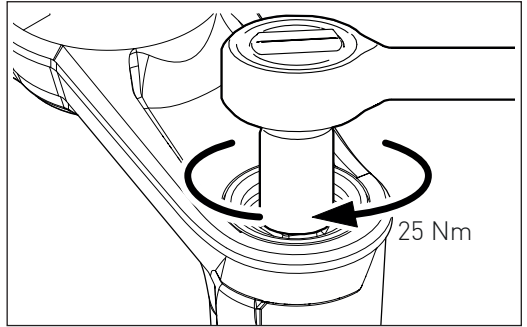
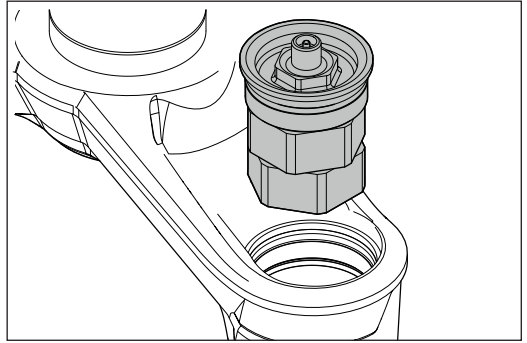

7.8 INFLATING THE FORK

1. Inflate the fork (see user manual for detailed information).
2. Screw on the valve cap.

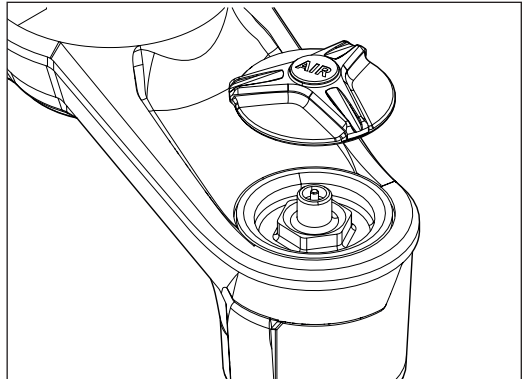

DT SWISS AG

Längfeldweg 101
CH - 2504 Biel/Bienne
service.ch@dtswiss.com

DT SWISS, INC.

2493 Industrial Blvd.
USA - Grand Junction, CO 81505
techusa@dtswiss.com

DT SWISS (FRANCE) S.A.S.

Parc d'Activites de la Sarrée
Route de Gourdon
F - 06620 Le Bar sur Loup
service.fr@dtswiss.com

DT SWISS ASIA LTD.

No.5, Jingke 5th Rd., Nantun District
Taichung City 408
Taiwan (R.O.C.)
service.tw@dtswiss.com

DT SWISS DEUTSCHLAND GmbH

Albert-Einstein-Strasse 3
59302 Oelde
Germany
service.de@dtswiss.com

DT SWISS POLSKA Sp. z o.o.

ul. Towarowa 36
PL-64-600 Oborniki
Poland
service.pl@dtswiss.com

Subject to technical alterations, errors and misprints excepted.

All rights reserved.

© by DT SWISS AG

www.dtswiss.com

FXD10000002583S